

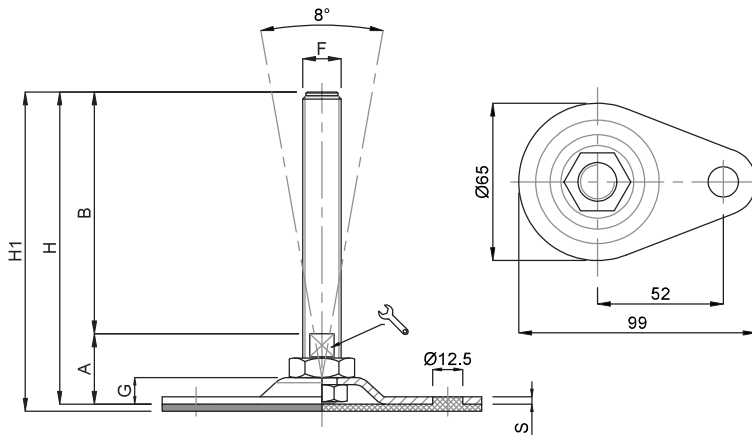



**Caratteristiche: BASE Ø 65 CON 1-2 FORI,
STELO SNODATO 8° O FISSO CON DADO**

**Features: BASE Ø 65 WITH 1-2 BORES,
8° ARTICULATED STEM OR FIX BY BOTTOM LOCKING NUT**

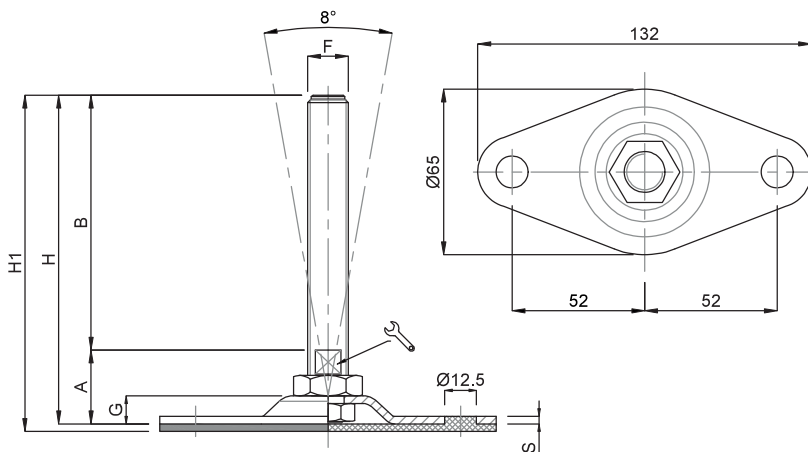

CODICE - CODE		descrizione description	DIMENSIONI PRINCIPALI - MAIN DIMENSIONS								CARICO STATICO STATIC LOAD NEWTON
Standard Standard	Antiscivolo Antislip		S	B	A		F	G	H	H1	
15840	15840/G	M16x150	3	150	29	13	M16	11	179	182	20000
15842	15842/G	M16x200	3	200	29	13	M16	11	229	232	20000
15844	15844/G	M20x150	3	150	32	17	M20	11	182	185	20000
15846	15846/G	M20x200	3	200	32	17	M20	11	232	235	20000



CODICE - CODE		descrizione description	DIMENSIONI PRINCIPALI - MAIN DIMENSIONS								CARICO STATICO STATIC LOAD NEWTON
Standard Standard	Antiscivolo Antislip		S	B	A		F	G	H	H1	
15848	15848/G	M12x100	3	100	28	10	M12	11	128	131	15000
15850	15850/G	M12x150	3	150	28	10	M12	11	178	181	15000
15852	15852/G	M16x100	3	100	29	13	M16	11	129	132	20000
15854	15854/G	M16x150	3	150	29	13	M16	11	179	182	20000
15856	15856/G	M16x200	3	200	29	13	M16	11	229	232	20000
15858	15858/G	M20x150	3	150	32	17	M20	11	182	185	20000
15860	15860/G	M20x200	3	200	32	17	M20	11	232	235	20000

• Base stampata in acciaio inox AISI 304. Stelo acciaio inox AISI 304. Su richiesta l'elemento di livellamento viene fornito con dado in acciaio

• Material: stainless steel base 1.4301. Stainless steel screw 1.4301. The levelling element could be supplied with steel nut.